

LED-8033 Post Top / Site / Wall Pack

SKU (USA)	SKU (Canada)	
LED-8033E30	LED-8033E30C	38W 3000K
LED-8033E42	LED-8033E42C	38W 4200K
LED-8033E57	LED-8033E57C	38W 5700K

Technical Specifications			
Models US/CAN	LED-8033E30/ LED-8033E30C	LED-8033E42/ LED-8033E42C	LED-8033E57/ LED-8033E57C
CCT	3000K	4200K	5700K
Power Consumption	38 watts		
Replaces	175w MH/HPS		
Mounting	E26		
Voltage	120-277VAC (USA) 120-347VAC (CANADA)		
LED Type	153 Samsung #5630 SMD		
Beam Angle	360		
Dimmable	No		
Operating Temp	-40°F - +122°F		
Rated R70 Life	Up to 50,000 Hrs.		
Warranty	5 Year Limited*		
LM79 Specifications	No	Yes	Yes
Power (W)	38	37.6	38.3
CCT		4315	5576
Light Output	3889	4366	4275
Efficacy	100	116	116
THD @ 277V	n/a	11.19%	12.23%
PF @ 277V	>90	0.98	0.919
CRI:	>80	84.5	86.4
R9	n/a	16	34
Duv	n/a	-0.0006	-0.0026
Packaging	9 / Master Carton		
Unit	4.7" x 4.7" x 11.42" 1.58 lbs.		
Master	14.8" x 14.7" x 9.7" 15.4 lbs.		

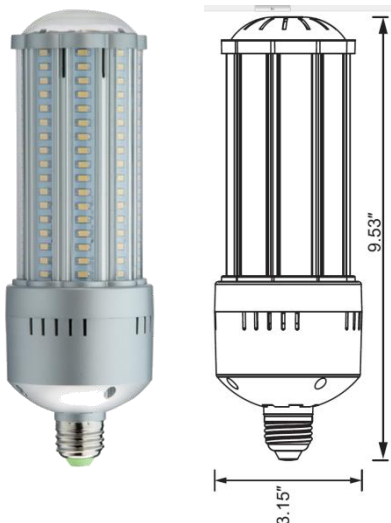

38W
LED for HID
Replaces
175W
MH / HPS



Description:

38W LED retrofit lamp to replace MH and HPS lamps up to 175w, E26 Medium base. Integrated insect/dust screen. UL damp rated approved for fully enclosed fixtures.

Features:

- Replaces 175w HID Lamps
- 120-277V or 120-347V (Canada)
- UL Classified for damp environments (USA & Canada)
- UL approved for fully enclosed fixtures (USA & Can)
- Active Cooling Fan >70,000 hr. rated life
- 50,000 rated life
- 5 year limited warranty (see website for details)

Applications:



Wall Pack Shoe Box Post Top

Installation Notes:

- When installing LED-8000 series retrofit lamps within HID fixtures, **ballast must be bypassed** when present.
- 8000 series retrofits are UL damp rated, sealing the fixtures after installation will deliver best results.
- **Installing surge/lightning protectors is highly recommended** and helps to eliminate premature driver failure caused by surges and other power fluctuations.

Note: All specification information falls within a ± 2% range and is subject to change without notice.
NOTE: Light Efficient Design is providing this information to the general public. Please note that all products contained herein are trademarked, copyrighted, and/or have patents pending. Any use of these designs is strictly prohibited without prior written consent. Light Efficient Design protects its proprietary information vigorously in the courts of the United States of America.